

DATASHEET



AMPIFARM | AF-C10-CY-425-NCPB-250

LARGE ENERGY STORAGE SYSTEM

The Ampifarm Series Energy Storage System is a large-scale solution that combines the Battery, BMS, and PCS to provide a maximum output of 2,060kWh per unit. It is enclosed in a containerized housing of either 10 or 20ft and features a distinctive air duct design, efficient temperature controls, and fire suppression technology.

The system is equipped with advanced controls that manage temperature, efficiency, lifespan, automated balancing, safety, and power delivery. Ampowr's Energy Storage Systems are engineered to meet even the most rigorous demands and withstand adverse conditions.

DATASHEET

SYSTEM TOPOLOGY

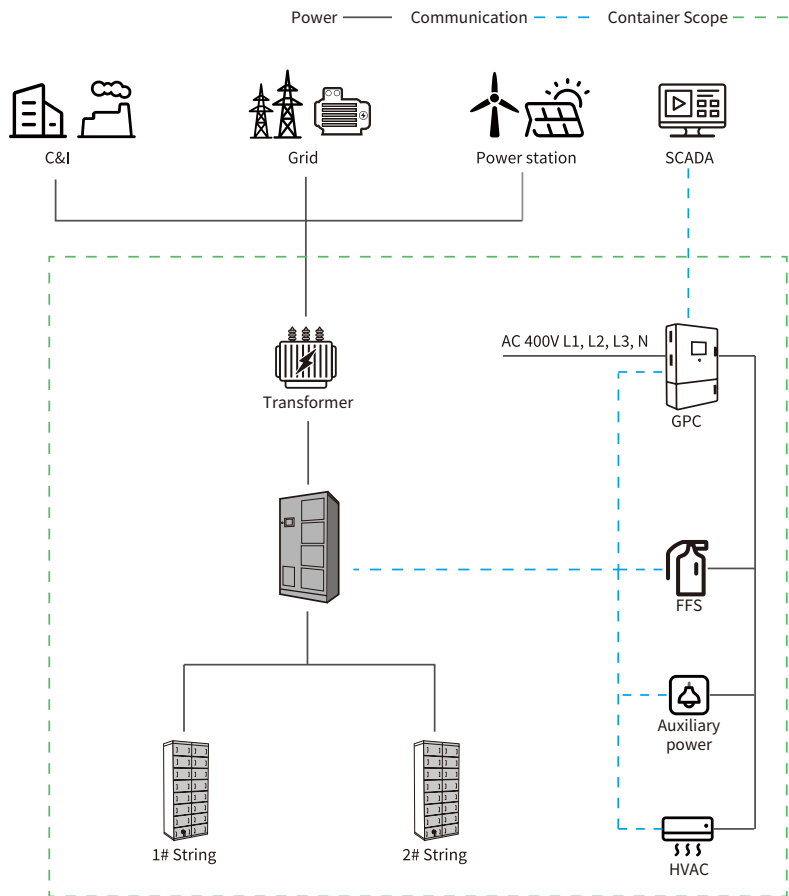

PRODUCT LAYOUT

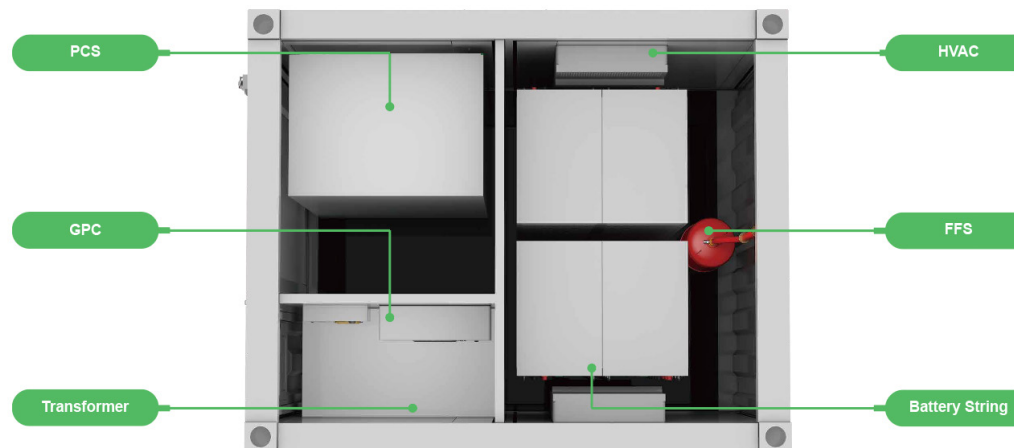

SYSTEM CONFIGURATION

Battery string type	Nominal capacity	AC connection	Isolation	Grid-connected voltage options	Dimensions (WDH mm)
NCPB-41P51373S	425kWh	3-Phase 4-Wire+PE	Built-in Transformer	480V 400V	2,991x 2,438x2,591mm

More Energy	All-in-one Design	Simple O&M	Safe & Reliable
Pack-level Optimization String-level Optimization	AC/DC All-in-one Design Reducing Initial Investment	No periodic balancing No experts site visit	Modular Design High Availability

DATASHEET



DC DATA

BATTERY CHEMISTRY	Lithium Iron Phosphate (LFP)
CELL LIFE CYCLE	80% Retention with 5,000 Cycles @ 0.5C 25 °C
CELL SPEC	3.2V/280Ah
STRING CONFIGURATION	1P240S
NUMBER OF STRINGS	2
RATED ENERGY CAPACITY	425kWh
DC RATED ENERGY CAPACITY	430.08kWh
RATED VOLTAGE	768V
VOLTAGE RANGE	672V~852V
BMS COMMUNICATION INTERFACE	RS485, Ethernet
BMS COMMUNICATION PROTOCOL	Modbus RTU, Modbus TCP

AC DATA

RATED AC POWER	200kW
MAXIMUM AC POWER	250W
RATED VOLTAGE	480V 400V
GRID VOLTAGE RANGE	423~528V 340~460V
AC RATE OF CURRENT	240.5A 288.6A
OUTPUT THDI	< 3%
AC PF	0.1~1 leading or lagging (Controllable)
AC OUTPUT	3-Phase 4-Wire+PE

GENERAL DATA

DIMENSION W/O CLEARANCES (L*W*H)	2,991 x 2,438 x 2,591mm
WEIGHT OF THE WHOLE SYSTEM	11t
DEGREE OF PROTECTION	IP54
OPERATING TEMPERATURE RANGE	-20~40 °C
RELATIVE HUMIDITY	0~95% (non-condensing)
MAX WORKING ALTITUDE	3,000m / 10,000feet (>2000m/6500feet derating)
COOLING CONCEPT OF DC HATCH	HVAC
FIRE FIGHTING SYSTEM	NOVEC1230 / FM-200
COMMUNICATION INTERFACES	RS485, Ethernet, GPRS
CERTIFICATES	UL9540, IEC62933, UN3536

DATASHEET



- 0.5C Charge/Discharge;
- Power supply can be single battery string or parallel battery strings;
- Easy configuration and maintenance

Battery String

BATTERY MODULE	NCPB1389P51
PACK QTY	15
NOMINAL CAPACITY	215.04kWh
RATED VOLTAGE	768V
DC VOLTAGE RANGE	672V~852V
PACK	25.6V/280Ah@1P16S
COMMUNICATION	Ethernet, CAN, RS485
LIFESPAN	>5,000 cycles@0.5C, 25°C
DIMENSIONS (W×D×H)	960 × 750 × 2,150mm
WEIGHT	1,872kg
CERTIFICATIONS	UL1973, UL9540A, IEC62619, CE , UN38.3



- Single-stage three-level modularization;
- Multi-branch input to reduce battery series and parallels connection;

Power Conversion System

BATTERY VOLTAGE RANGE	500-850V	
DC MAX CURRENT	440A	
RATED AC POWER	200kW	
MAXIMUM AC POWER	250kW	
RATED VOLTAGE	480V	400V
GRID VOLTAGE RANGE	432-528V	340-460V
AC RATE OF CURRENT	240.5A	288.6A
OUTPUT THDI	≤3%	
ADJUSTABLE PF	1(leading)~1(lagging)	
GRID FREQUENCY RANGE	60Hz(59.5~60.5Hz)	50/60±2.5Hz
ISOLATION METHOD	Built-in Transformer	
DIMENSIONS (W×D×H)-PCS	1,200 x 800 x 2,160mm	
WEIGHT	1,280kg	



- All-round signal collection;
- Comprehensive logical control;
- Multilevel electric & control protection;
- Intelligentize Communication management;
- Simple Configuration.

GridPoint Controller (GPC)

POWER INTERFACE	AC220V/DC24V
COMMUNICATION	Modbus RTU, Modbus TCP
RELAY	24 stem node input / output
NETWORK CONTROL APPLICATION	Peak shifting and valley filling, peak cutting, smooth renewable energy output curve
OFFLINE CONTROL APPLICATION	Backup power supply, PV/DG/EV/ESS integrated micro-grid control

DATASHEET

BMS with Real-time Passive Balance

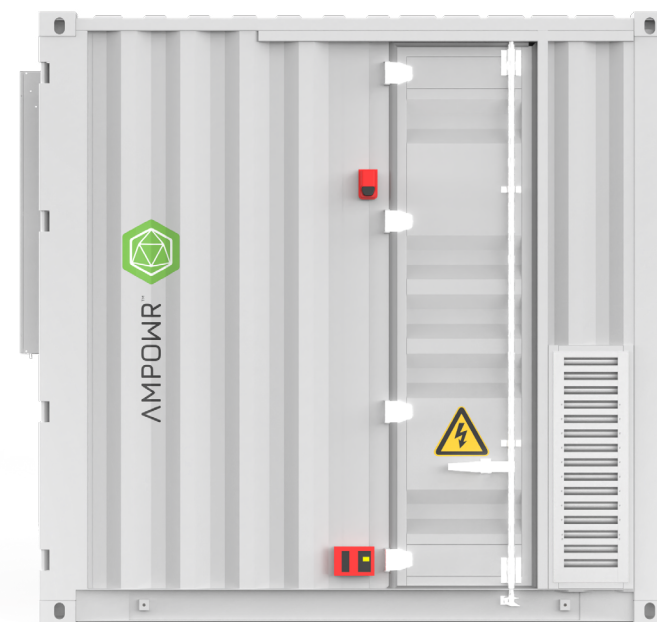
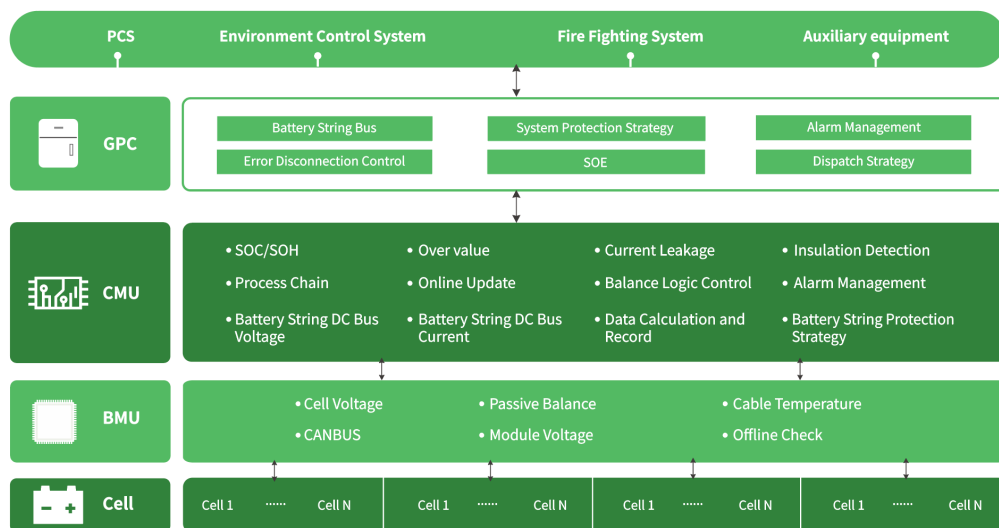

BMU		CMU	
Cell Voltage Measurement Accuracy	±5 mV	Battery String Voltage Measurement Range	100~1,000V
Cell Voltage Monitoring Interval	≤200ms	Battery String Voltage Measurement Accuracy	±1%
Cell Temperature Measurement Accuracy	±2℃	Battery String Voltage Monitoring Interval	≤100ms
Cell Temperature Measurement Interval	≤3s	Battery String Current Measurement Range	±300A
Cell Current Balance	Passive Balance, 150mA MAX	Battery String Current Measurement Accuracy	≤1%
Cell Voltage Measurement Range	1~5 V	Battery String Current Monitoring Interval	≤50ms
Over-current Protection	250A/1s	SOC Calculation Accuracy	≤8%
Short-Circuit Protection	500A/10ms	Input Insulation Resistance	≥10MΩ, 1,000VDC

© 2022 BY AMPOWR B.V. ALL RIGHTS RESERVED.

This document is proprietary to and copyright of Ampowr B.V. This document cannot be copied or reproduced in whole or in part without the express written permission of Ampowr B.V. Ampowr reserves the right to make updates and changes to any and all product-related documentation with or without informing distributors, resellers, and users. Please check our website (www.ampowr.com) regularly for literature updates, document changes, and profile updates.

ampowr.com | info@ampowr.com

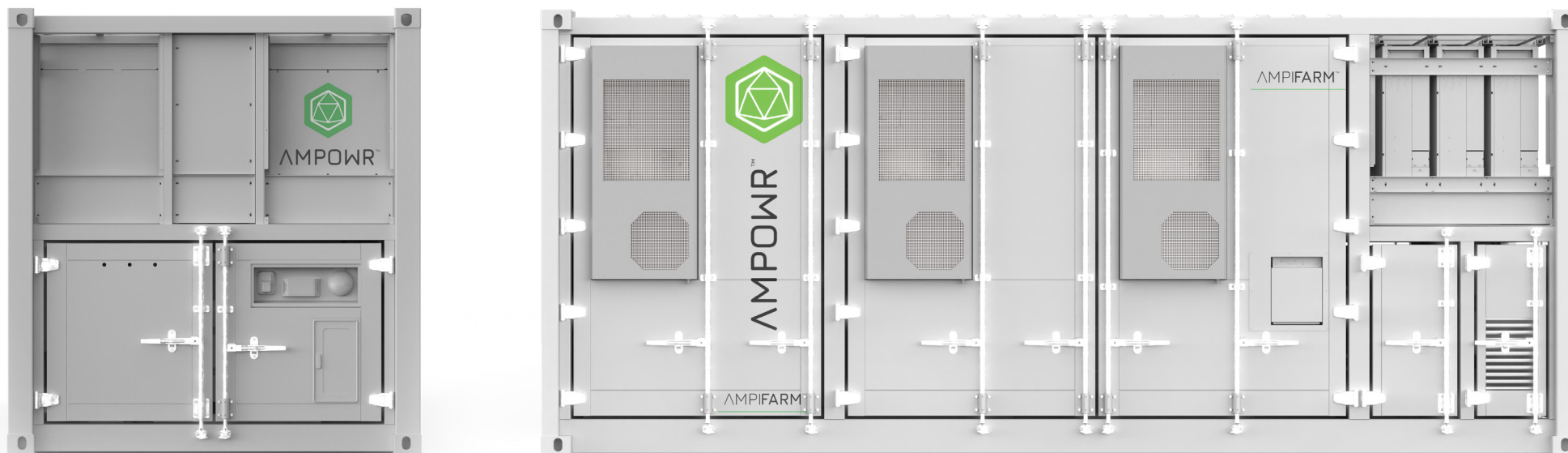

AMPIFARM | AF-C20-CY-550-NCPB-500

LARGE ENERGY STORAGE SYSTEM

The AmpoFARM Series Energy Storage System is a large-scale solution that combines the Battery, BMS, and PCS to provide a maximum output of 2,060kWh per unit. It is enclosed in a containerized housing of either 10 or 20ft and features a distinctive air duct design, efficient temperature controls, and fire suppression technology.

The system is equipped with advanced controls that manage temperature, efficiency, lifespan, automated balancing, safety, and power delivery. Ampowr's Energy Storage Systems are engineered to meet even the most rigorous demands and withstand adverse conditions.

DATASHEET

SYSTEM TOPOLOGY

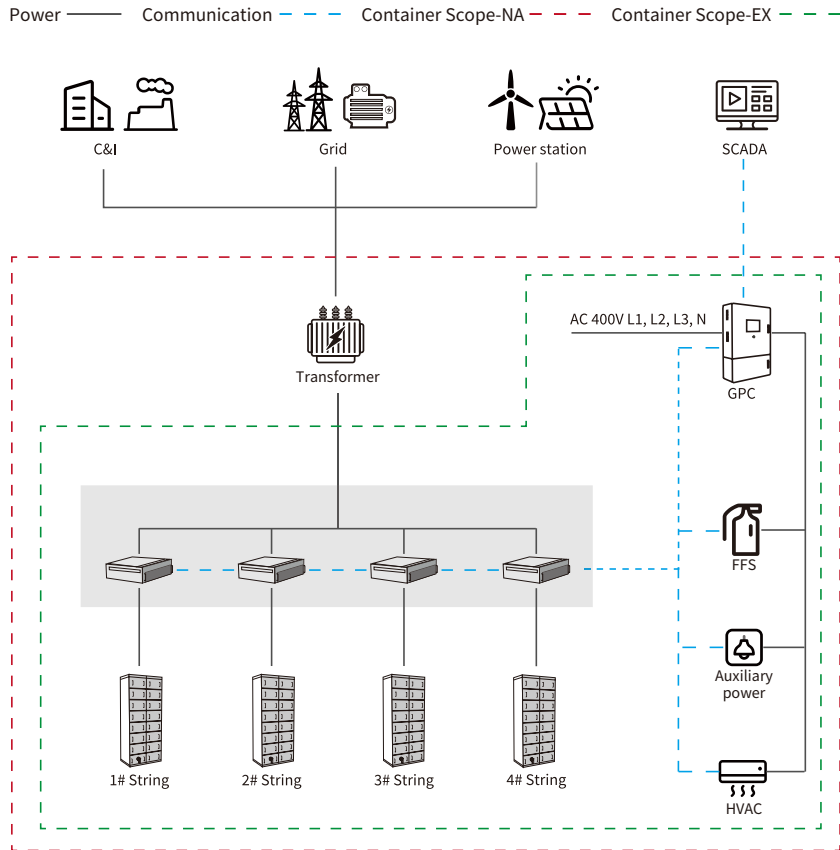

PRODUCT LAYOUT

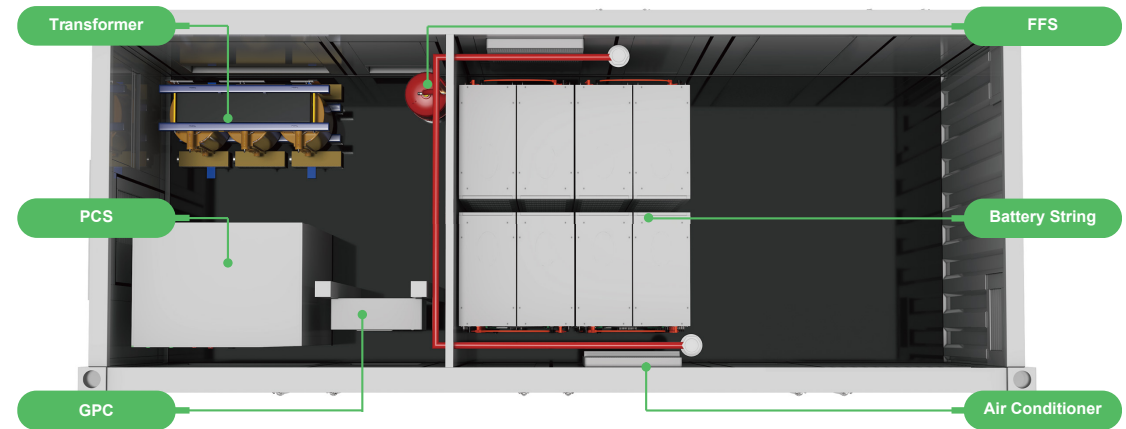

SYSTEM CONFIGURATION

Product Model	Battery string type	Pack Qty	Nominal Capacity	AC Connection	Isolation	Grid-connected voltage	Dimensions (WxDxH)
AF-C20-CY-550-NCPB-500-U	NCPB-41P42373S	15	550kWh	3-Phase 4-Wire+PE	Built-in Transformer	480V	6,058 x 2,438 x 2,591mm
AF-C20-CY-550-NCPB-500-E				3-Phase+PE	Non-isolation	400V	

Powerful System	All-in-one Design	Simple O&M	Safe & Reliable
Pack-level Optimization String-level Optimization	AC/DC. All-in-one Compact Design. (Batteries, PCS)	No periodic balancing. No frequent expert site visits.	Modular Design, Safe Battery tech, High Availability

DATASHEET

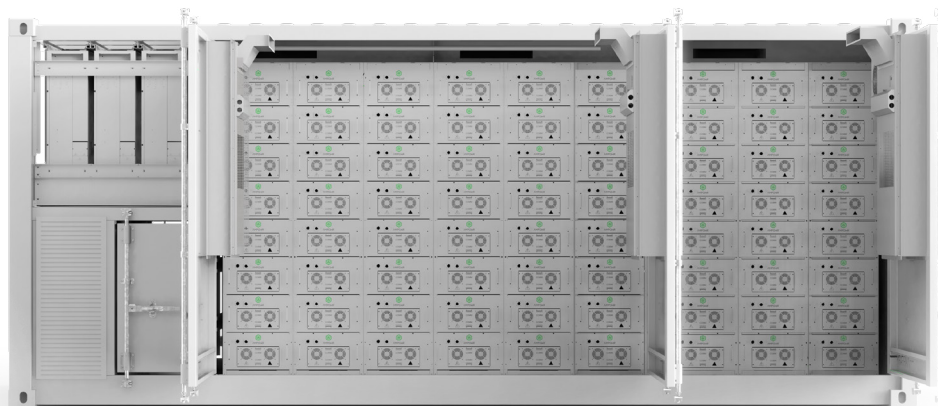

DC DATA

BATTERY CHEMISTRY	Nano Crystal Batteries Lithium Iron Phosphate (LFP)
CELL LIFE CYCLE	80% Retention with 5,000 Cycles @ 1C 25 °C
CELL SPEC	3.2V/90Ah
STRING CONFIGURATION	2P240S
NUMBER OF STRINGS	4
RATED ENERGY CAPACITY	550kWh
DC RATED ENERGY CAPACITY	552.96kWh
RATED VOLTAGE	768V
VOLTAGE RANGE	672V~852V
BMS COMMUNICATION INTERFACE	RS485, Ethernet
BMS COMMUNICATION PROTOCOL	Modbus RTU, Modbus TCP

AC DATA

SYSTEM	AF-C20-CY-550-NCPB-500-U	AF-C20-CY-550-NCPB-500-E
RATED AC POWER	500kW	
MAXIMUM AC POWER	550kW	
RATED VOLTAGE	480V	400V
GRID VOLTAGE RANGE	432~528V (Configurable)	342~418V (Configurable)
AC RATE OF CURRENT	601.4A	721.7A
OUTPUT THDI	< 3%	
AC PF	0.1~1 leading or lagging (Controllable)	
AC OUTPUT	3-Phase 4-Wire+PE	3-Phase+PE

GENERAL DATA

	AF-C20-CY-550-NCPB-500-N	AF-C20-CY-550-NCPB-500-E
DIMENSION W/D CLEARANCES (L*W*H)	6,058 x 2,438 x 2,591mm	
WEIGHT OF THE WHOLE SYSTEM	14.5t	13.2t
DEGREE OF PROTECTION	IP54	
OPERATING TEMPERATURE RANGE	-20~40 °C	
RELATIVE HUMIDITY	0~95% (non-condensing)	
MAX WORKING ALTITUDE	3,000m / 10,000feet (> 2000m/6500feet derating)	
COOLING CONCEPT OF DC HATCH	HVAC	
FIRE FIGHTING SYSTEM	NOVEC1230 / FM-200	
COMMUNICATION INTERFACES	RS485, Ethernet, GPRS	
CERTIFICATES	UL9540, IEC62933, UN3536	

DATASHEET

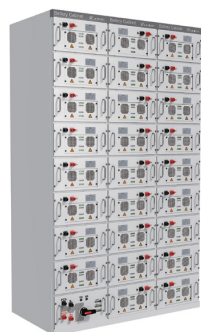

- 1C Charge/Discharge;
- Power supply can be single battery string or parallel battery strings;
- Easy configuration and maintenance.



- Single-stage three-level modularization;
- Multi-branch input to reduce battery series and parallels connection;



- All-round signal collection;
- Comprehensive logical control;
- Multilevel electric & control protection;
- Intelligentize Communication management;
- Simple Configuration.

Battery String

BATTERY MODULE	NCPB1389P51
PACK QTY	15
NOMINAL CAPACITY	138.24kWh
RATED VOLTAGE	768V
DC VOLTAGE RANGE	672V~852V
PACK	25.6V/180Ah@2P16S
COMMUNICATION	Ethernet, CAN, RS485
LIFESPAN	>5,000 cycles @1C, 25℃
DIMENSIONS (W*D*H)	800 × 750 × 2,050mm
WEIGHT	1,467kg
CERTIFICATIONS	UL1973, UL9540A, IEC62619, CE , UN38.3

Power Conversion System

	AP-AN-LTK005-1SWP	AP-XE-LTK005-1SWP
BATTERY VOLTAGE RANGE	630~900V	600~900V
DC MAX CURRENT	873A	
RATED AC POWER	500kW	
MAXIMUM AC POWER	550kW	
RATED VOLTAGE	480V	400V
GRID VOLTAGE RANGE	432~528V	342~418V
AC RATE OF CURRENT	601.4A	721.7A
OUTPUT THDI	≤3%	
ADJUSTABLE PF	1(leading)~1(lagging)	
GRID FREQUENCY RANGE	60Hz (59.5~60.5Hz)	50/60±2.5Hz
ISOLATION METHOD	Built-in Transformer	Non-isolation
DIMENSIONS (W*D*H)-PCS	2,200 × 800 × 2,160mm	1,100 × 800 × 2,160mm
DIMENSIONS (W*D*H)-TRANSFORMER	1,100 × 625 × 810mm	/
WEIGHT	2,000kg	600kg

GridPoint Controller (GPC)

POWER INTERFACE	AC220V / DC24V
COMMUNICATION	Modbus RTU, Modbus TCP
RELAY	24 stem node input / output
NETWORK CONTROL APPLICATION	Peak shifting and valley filling, peak cutting, smooth renewable energy output curve
OFFLINE CONTROL APPLICATION	Backup power supply, PV/DG/EV/ESS integrated micro-grid control

DATASHEET

BMS with Real-time Passive Balance

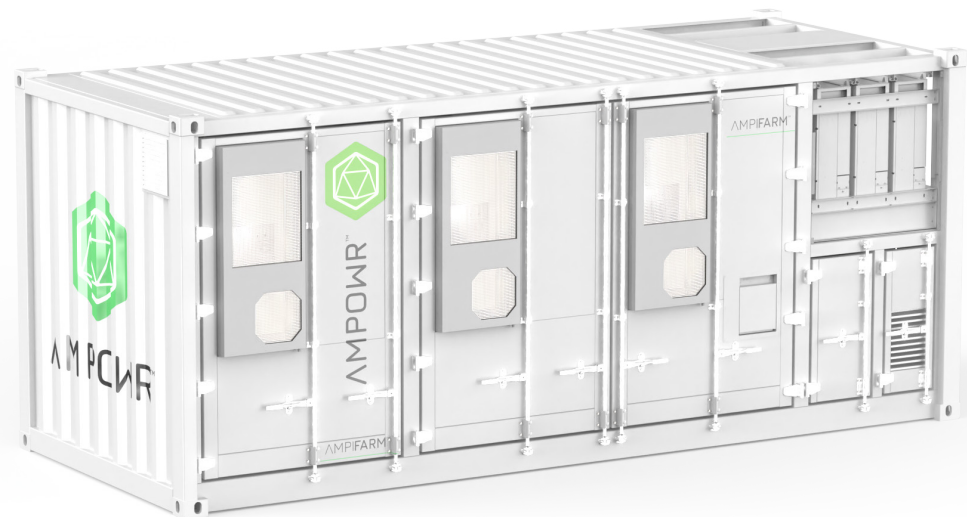
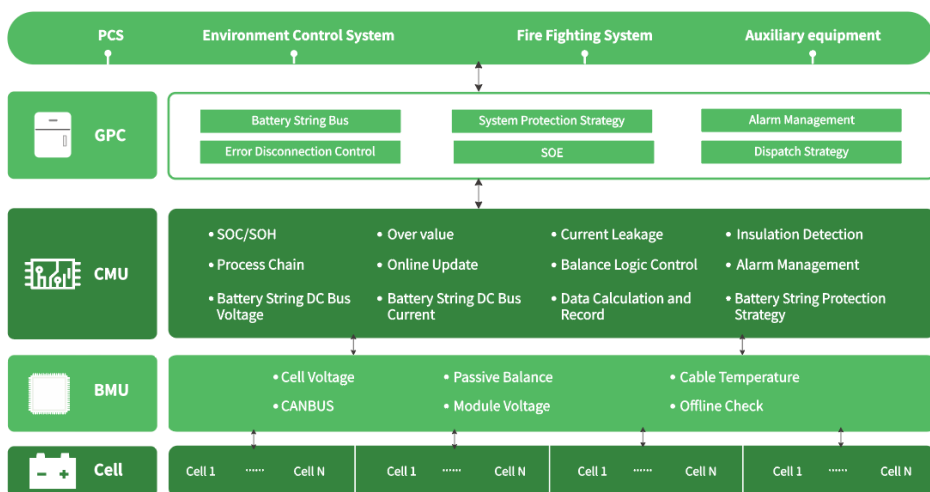

BMU		CMU	
Cell Voltage Measurement Accuracy	±5 mV	Battery String Voltage Measurement Range	100~1,000Vv
Cell Voltage Monitoring Interval	≤200ms	Battery String Voltage Measurement Accuracy	±1%
Cell Temperature Measurement Accuracy	±2 °C	Battery String Voltage Monitoring Interval	≤100ms
Cell Temperature Measurement Interval	≤3s	Battery String Current Measurement Range	±300A
Cell Current Balance	Passive Balance, 150mA MAX	Battery String Current Measurement Accuracy	≤1%
Cell Voltage Measurement Range	1~5 V	Battery String Current Monitoring Interval	≤50ms
Over-current Protection	250A/1s	SOC Calculation Accuracy	≤8%
Short-Circuit Protection	500A/10ms	Input Insulation Resistance	≥10MΩ, 1,000VDC

© 2022 BY AMPOWR B.V. ALL RIGHTS RESERVED.

This document is proprietary to and copyright of Ampowr B.V. This document cannot be copied or reproduced in whole or in part without the express written permission of Ampowr B.V. Ampowr reserves the right to make updates and changes to any and all product-related documentation with or without informing distributors, resellers, and users. Please check our website (www.ampowr.com) regularly for literature updates, document changes, and profile updates.

ampowr.com | info@ampowr.com

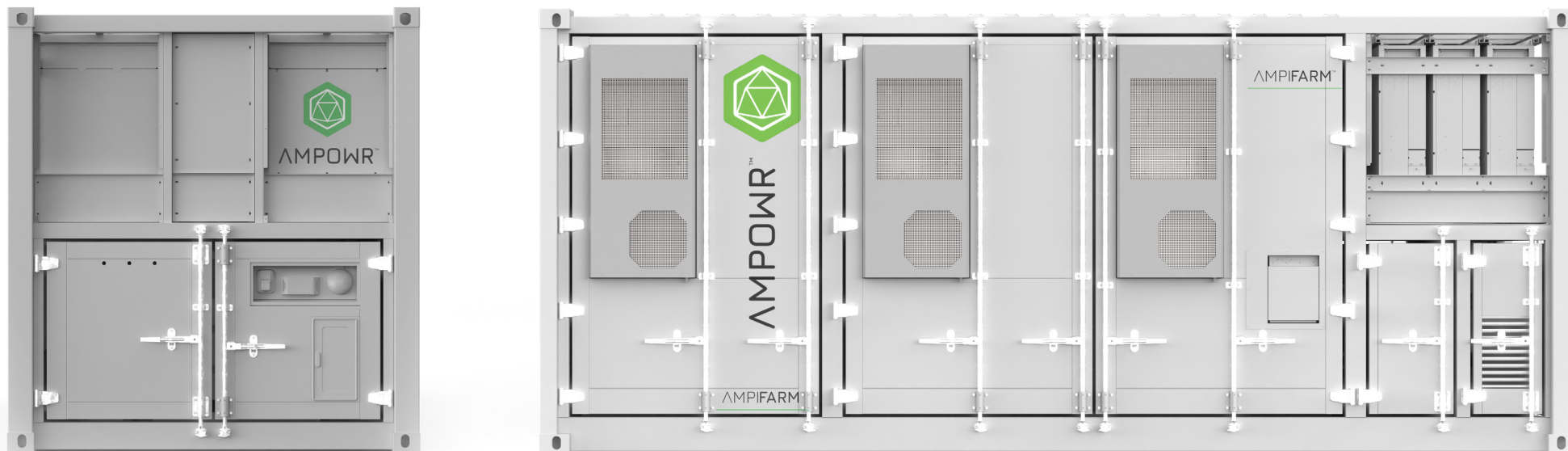

AMPIFARM | AF-C20-CY-2060-NCPB-1000

LARGE ENERGY STORAGE SYSTEM

The AmpoFARM Series Energy Storage System is a large-scale solution that combines the Battery, BMS, and PCS to provide a maximum output of 2,060kWh per unit. It is enclosed in a containerized housing of either 10 or 20ft and features a distinctive air duct design, efficient temperature controls, and fire suppression technology.

The system is equipped with advanced controls that manage temperature, efficiency, lifespan, automated balancing, safety, and power delivery. AmpoFARM's Energy Storage Systems are engineered to meet even the most rigorous demands and withstand adverse conditions.

DATASHEET

SYSTEM TOPOLOGY

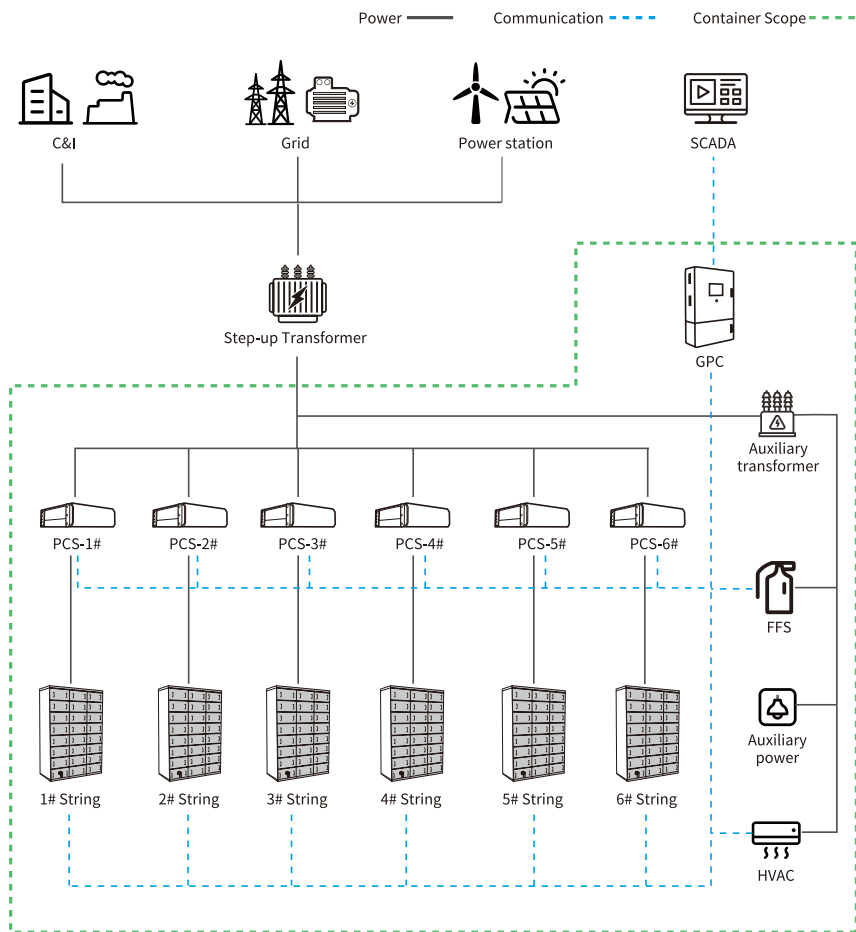

PRODUCT LAYOUT

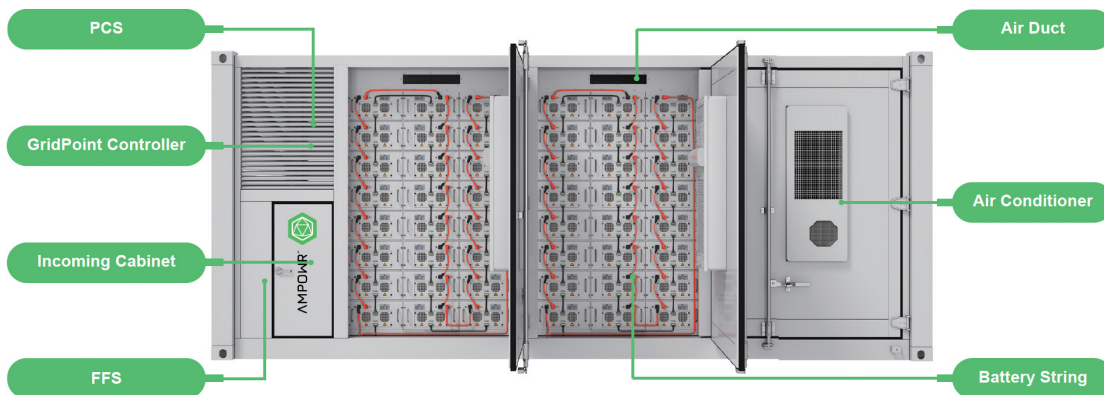

SYSTEM CONFIGURATION

Product Model	Battery string type	String Quantity	Nominal Capacity	DC Voltage Range	Grid-connected voltage	Dimensions (WDH mm)
AF-C20-CY-2060-NCPB-1000	NCPB-41P42373S	6	2,064kWh	1,075.2V ~ 1,363.2V	690V	6,058 x 2,438 x 2,591mm

Powerful System	All-in-one Design	Simple O&M	Safe & Reliable
Pack-level Optimization String-level Optimization	AC/DC. All-in-one Compact Design. (Batteries, PCS)	No periodic balancing. No frequent expert sitevisits.	Modular Design, Safe Battery tech, High Availability

DATASHEET

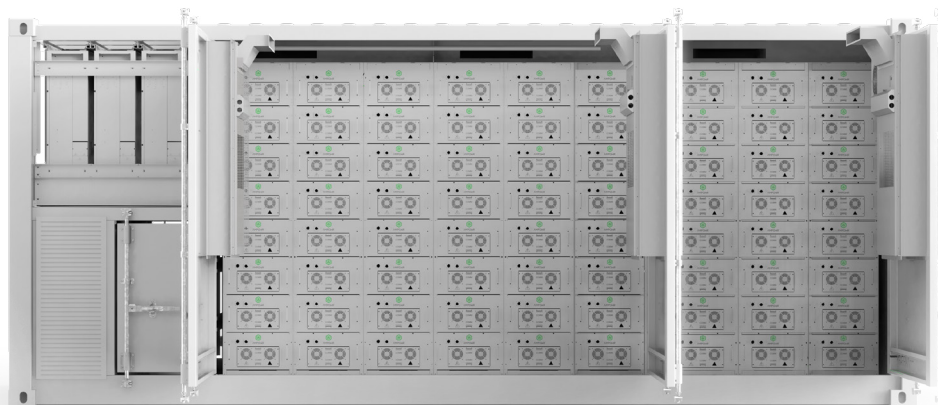

DC DATA

BATTERY CHEMISTRY	Nano Crystal Batteries Lithium Iron Phosphate (LFP)
CELL LIFE CYCLE	80% Retention with 5,000 Cycles @ 0.5C 25 °C
CELL SPEC	3.2V/280Ah
STRING CONFIGURATION	1P384S
NUMBER OF STRINGS	6
RATED ENERGY CAPACITY	2,060kWh
DC RATED ENERGY CAPACITY	1,228.8V
RATED VOLTAGE	1,075.2V ~ 1,363.2V
VOLTAGE RANGE	672V~852V
BMS COMMUNICATION INTERFACE	RS485, Ethernet
BMS COMMUNICATION PROTOCOL	Modbus RTU, Modbus TCP

AC DATA

SYSTEM	AF-C20-CY-2060-NCPB-1000
RATED AC POWER	1,000kW
MAXIMUM AC POWER	1,200kW
RATED VOLTAGE	690V
GRID VOLTAGE RANGE	586.5~759V (Optional)
AC RATE OF CURRENT	836.8A
OUTPUT THDI	< 3%
AC PF	0.1~1 leading or lagging (Controllable)
AC OUTPUT	3P+PE

GENERAL DATA

	AF-C20-CY-2060-NCPB-1000
DIMENSION W/D CLEARANCES (L*W*H)	6,058 x 2,438 x 2,591mm
WEIGHT OF THE WHOLE SYSTEM	24t
DEGREE OF PROTECTION	IP65 - Battery room, IP54 - PCS room
OPERATING TEMPERATURE RANGE	-20~40 °C
RELATIVE HUMIDITY	0~95% (non-condensing)
MAX WORKING ALTITUDE	4,000m / 13,123ft
COOLING CONCEPT OF DC HATCH	HVAC
FIRE FIGHTING SYSTEM	NOVEC1230 / FM-200
COMMUNICATION INTERFACES	RS485, Ethernet, GPRS
CERTIFICATES	UL9540 IEC62619, IEC62109, IEC62933, UN3536

DATASHEET



- 0.5C Charge/Discharge;
- Power supply can be single battery string or parallel battery strings;
- Easy configuration and maintenance.



- Single-stage three-level modularization;
- Multi-branch input to reduce battery series and parallels connection;



- All-round signal collection;
- Comprehensive logical control;
- Multilevel electric & control protection;
- Intelligentize Communication management;
- Simple Configuration.

Battery String

BATTERY MODULE	NCPB41P42-373S
PACK QTY	24
NOMINAL CAPACITY	344.096kWh
RATED VOLTAGE	1,228.8V
DC VOLTAGE RANGE	1,075.2V ~ 1,363.2V
PACK	25.6V/180Ah@2P16S
COMMUNICATION	Ethernet, CAN, RS485
LIFESPAN	>5,000 cycles @0.5C, 25℃
DIMENSIONS (W×D×H)	1,440 × 750 × 2,150mm
WEIGHT	2,922kg
CERTIFICATIONS	UL1973, UL9540A, IEC62619, CE , UN38.3

Power Conversion System

	AP-XE-LTK0001-1SWP
DC VOLTAGE RANGE	1000~1,500V
DC MAX CURRENT	224.5A * 6
RATED AC POWER	200kW * 6
RATED VOLTAGE	690V
GRID VOLTAGE RANGE	-15%~+10%
GRID FREQUENCY	50Hz/60Hz
MAX AC CURRENT	184.1A * 6
AC PF	0.1~1 leading or lagging (controllable)
WEIGHT	100kg * 6
CERTIFICATIONS	UL 1741, IEEE 1547, IEC62477-1, IEC 61000

GridPoint Controller (GPC)

POWER INTERFACE	AC220V/DC24V
COMMUNICATION	Modbus RTU, Modbus TCP
RELAY	24 stem node input / output
NETWORK CONTROL APPLICATION	Peak shifting and valley filling, peak cutting, smooth renewable energy output curve
OFFLINE CONTROL APPLICATION	Backup power supply, PV/DG/EV/ESS integrated micro-grid control

DATASHEET

BMS with Real-time Passive Balance

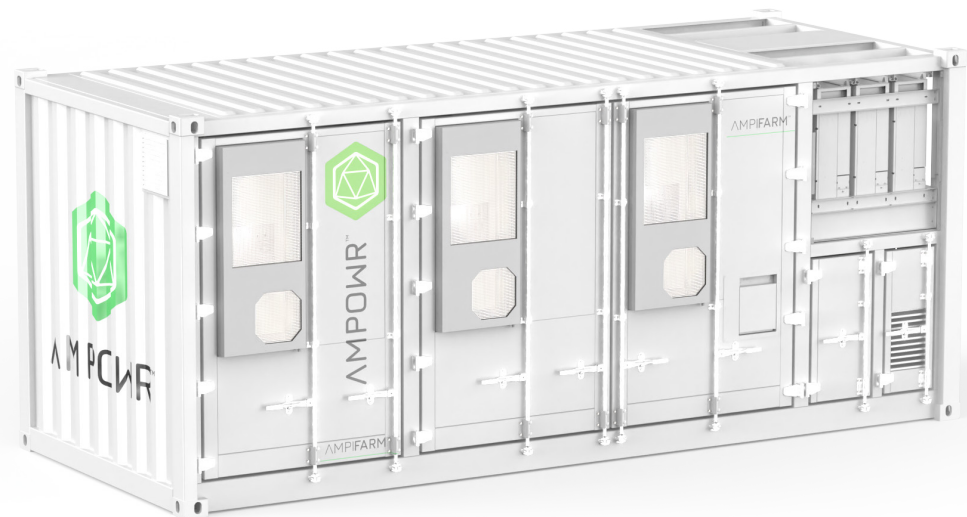
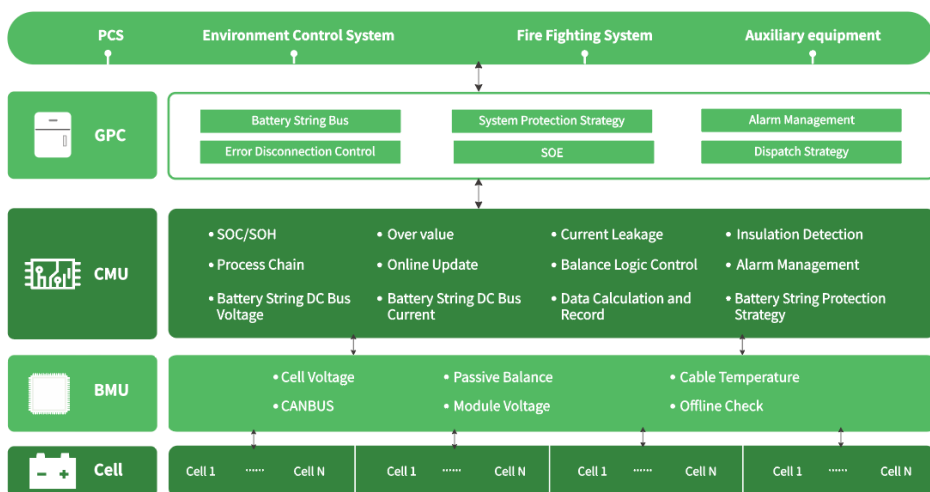

BMU		CMU	
Cell Voltage Measurement Accuracy	±5 mV	Battery String Voltage Measurement Range	100~1,000Vv
Cell Voltage Monitoring Interval	≤200ms	Battery String Voltage Measurement Accuracy	±1%
Cell Temperature Measurement Accuracy	±2 °C	Battery String Voltage Monitoring Interval	≤100ms
Cell Temperature Measurement Interval	≤3s	Battery String Current Measurement Range	±300A
Cell Current Balance	Passive Balance, 150mA MAX	Battery String Current Measurement Accuracy	≤1%
Cell Voltage Measurement Range	1~5 V	Battery String Current Monitoring Interval	≤50ms
Over-current Protection	250A/1s	SOC Calculation Accuracy	≤8%
Short-Circuit Protection	500A/10ms	Input Insulation Resistance	≥10MΩ, 1,000VDC

© 2022 BY AMPOWR B.V. ALL RIGHTS RESERVED.

This document is proprietary to and copyright of Ampowr B.V. This document cannot be copied or reproduced in whole or in part without the express written permission of Ampowr B.V. Ampowr reserves the right to make updates and changes to any and all product-related documentation with or without informing distributors, resellers, and users. Please check our website (www.ampowr.com) regularly for literature updates, document changes, and profile updates.

ampowr.com | info@ampowr.com



AMPIFARM™ ESS

AMPIFARM - 250KW / 700KWH ESS

The AmpifARM™ Series Energy Storage System integrates with the Battery, BMS, PCS to deliver a total power delivery of 700kWh. The AmpifARM™ is housed in a 20ft containerized housing which employs a unique air duct design, resourceful temperature control technology and state of the art FM200 fire suppression.

NO.	ITEM	SPECIFICATION	QTY	REMARK
1	AMPIFARM	250kW PCS / Battery 700kWH	1	Including 1.1-1.6
1.1	Power Conditioning System (PCS)	AMP-T0520-ESG, 400Vac / 50Hz, 3Ph+PE+N	1	
1.2	Local Controller	AMP-0001-SME; AMP-10-UME-KSM	1	
1.3	Battery System (Battery rack)	175kWh,0.5C Module(2P12S) 19S +1 control box, 729.6V/638.4~820.8V	4	Total 700kWh
1.4	Battery System (BMS)	Matched with battery system	1	
1.5	Container Enclosure	20' container with PCS chamber and battery chamber (including lighting and power distribution)	1	20ft container
1.6	Container HVAC	7.5kW	2	
1.7	Container Firefighting System	Including fire controller, FM200, smoke sensing, temperature sensing, alarm and other fire control systems	1	
1.8	DC Combiner Cabinet	AMP-8-1-SCDK	1	
1.9	AC&DC Cable	Cables for module connection	/	All required cables included
TOTAL PCS CAPACITY (KWH)			250	
TOTAL BATTERY CAPACITY (KWH)			700	



DATASHEET



BATTERY SILO

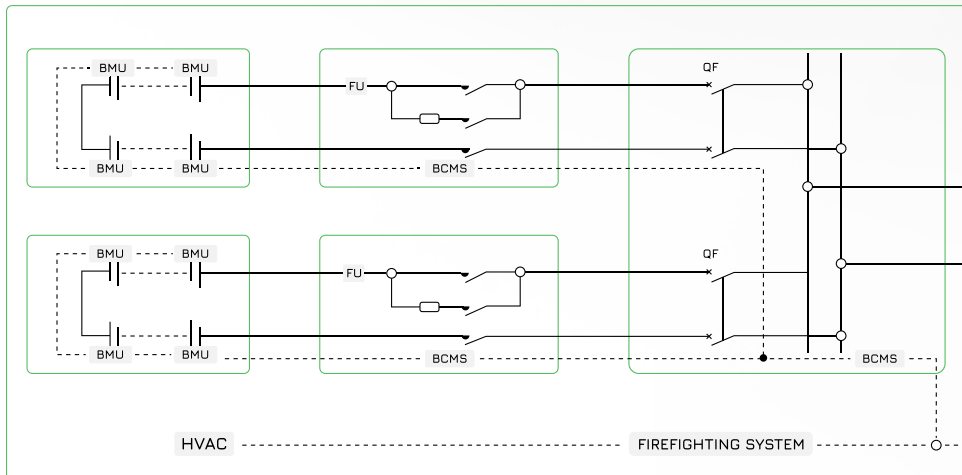

PCS SILO

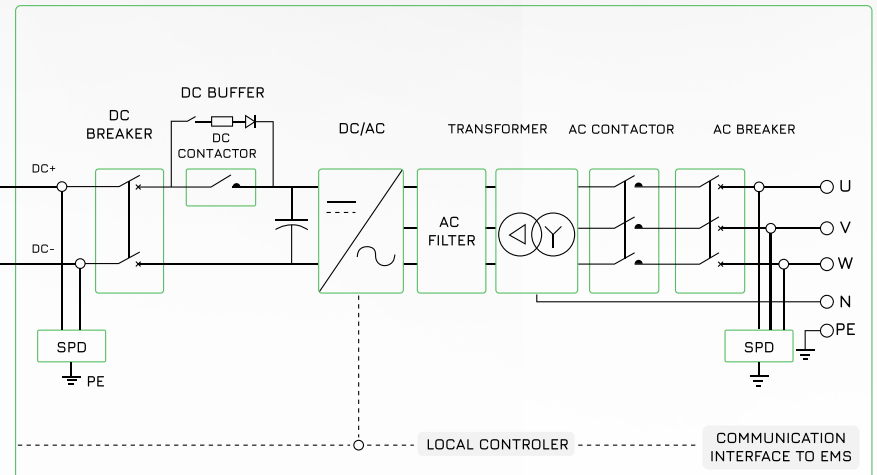



POWER CONDITIONING SYSTEM

AMP-T0520ESG (PCS)

DC SIDE

MAX. DC VOLTAGE	1000 V
DC VOLTAGE RANGE FOR NOMINAL POWER	500 ~ 850Vdc
MAX. DC CURRENT	565A
AUTO-BUFFER FUNCTION	Yes

AC SIDE (GRID)

AC OUTPUT POWER	250kW
MAX. AC POWER	275kVA
MAX. AC CURRENT	400A
NOMINAL AC VOLTAGE	400Vac, 3W+N+PE
AC VOLTAGE RANGE	400Vac (-20% ~ +15%)
NOMINAL GRID FREQUENCY (GRID FREQUENCY RANGE)	50/60Hz (± 2Hz)
AC CURRENT THD (TOTAL HARMONIC DISTORTION)	<3%
POWER FACTOR AT NOMINAL POWER	>0.99/1 leading – 1 lagging
ADJUSTABLE REACTIVE POWER	-100% ~ 100%

GENERAL DATA

DIMENSIONS (W X H X D)	1200 x 935 x 2000mm (63 x 36.8 x 78.7 inch)
WEIGHT	930kg (2050lbs)
BYPASS ATS MODULE	Optional
ISOLATION METHOD	Transformer
CHARGE/DISCHARGE SWITCHING TIME	<40ms
INGRESS PROTECTION RATING	IP21
OPERATING AMBIENT TEMPERATURE RANGE	-30 °C - +55 °C (-22 °F - +131 °F)
RELATIVE HUMIDITY RANGE	0~95% (no condensation)
COOLING METHOD	Intelligent forced air cooling
MAX. OPERATING ALTITUDE	5000m (>3000m derating)
DISPLAY	Touchscreen
COMMUNICATION	RS485 / CAN 2.0 (to BMS), RS485 / Ethernet (to EMS)
GRID SUPPORT	L/HVRT, L / HFRT, active & reactive power control and power ramp rate control

BATTERY SYSTEM

The energy storage system adopts a 3.2V / 120Ah Nano Crystal Battery Cell. The battery cell is packed into a battery module with a voltage of 38.4V and a capacity of 9.216kWh through two parallel strings in a series of 12. 14 modules are connected in series to form a battery rack with a voltage of 537.6V and a capacity of 129kWh. Each battery container system consists of 8 battery banks, with a total energy storage capacity of 700kWh.

NCPB3.2-120CL - BATTERY CELL

CAPACITY	≥ 120Ah @ 25 °C (77 °F), 0.25C, BOL	NOMINAL GRID FREQUENCY (GRID FREQUENCY RANGE)	50/60Hz (± 2Hz)
NOMINAL VOLTAGE	3.2V	REVERSIBLE CAPACITY LOSS, 25 °C (77 °F), 100% SOC / MONTH	≤ 3.5%
DIMENSION (W X H X D)	173.9 x 170 x 485mm (6.86 x 6.7 x 19.1inch)	OPERATION TEMPERATURE	-20 °C ~ 55 °C (-4 °F ~ 131 °F)
WEIGHT	≤2.86kg (6.3lbs)	STORAGE TEMPERATURE	-30 °C ~ 60 °C (-22 °F ~ 140 °F)
IMPEDANCE (1KHZ, BOL, 40% SOC)	≤0.3mΩ	CERTIFICATION	IEC 62619, UL1973, UN38.3

NCPB38.4-9.2BP - BATTERY PACK

NOMINAL ENERGY	9.216kWh @25 °C (77 °F), BOL, 2P12S	OPERATION TEMPERATURE	Min. 0 °C (32 °F) - Max. 40 °C (104 °F)
RATED VOLTAGE	38.4V	COOLING METHOD	Air Cooling
VOLTAGE RANGE	Min: 33.6V Max: 43.8V	HUMIDITY	0%~95%, non condensing
WEIGHT	86kg (189.6lbs)	COMMUNICATION PROTOCOL	Rack BMS: CAN;
DIMENSION (H X W X D)	202 x 642 x 676mm (8 x 25.3 x 26.6inch)	Note: CSC (Cel Sensor Circuit) includes passive balancing, cell voltage measurement, temperature measurement.	

BATTERY RACK

CONFIGURATION	(2P12S) 14S	DIMENSION (H X W X D)	2220 x 1080mm x 725 (87.4 x 42.5 x 28.5 inch)
NOMINAL ENERGY	129kWh @25 °C (77 °F), BOL, NCPB3.2-120CL	OPERATION TEMPERATURE	Min. 0 °C (32 °F) - Max. 40 °C (104 °F)
RATED VOLTAGE	537.6V	COOLING METHOD	Air Cooling
VOLTAGE RANGE	470.4V ~ 604.8V	HUMIDITY	0%~95%, non condensing
WEIGHT	~1850kg (<4078lbs)	COMMUNICATION PROTOCOL	Modbus + CAN

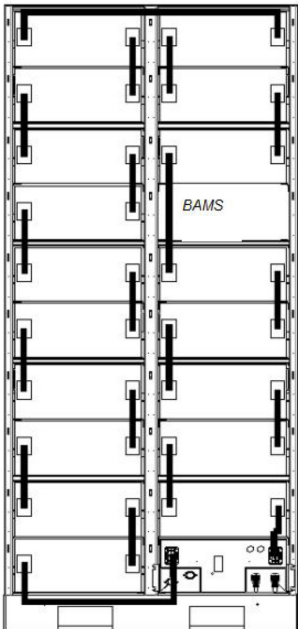

DATASHEET



CONTROL BOX WITH RACK BMS



BATTERY MANAGEMENT SYSTEM

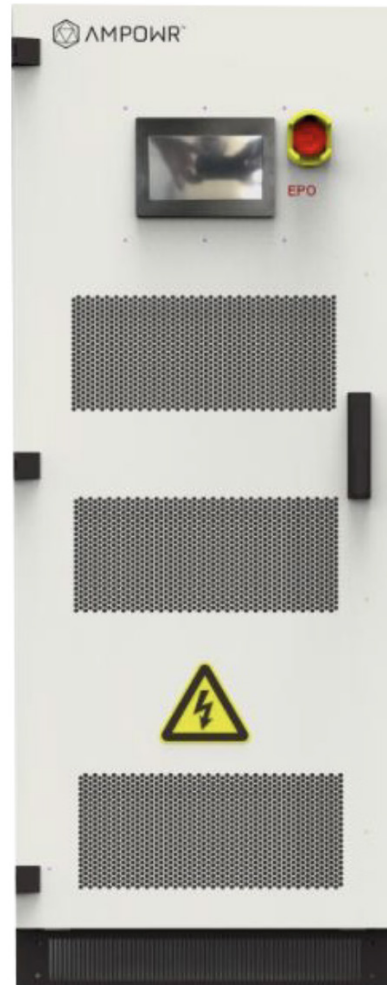

LOCAL CONTROLLER CABINET

BATTERY MANAGEMENT

The rack BMS has the ability to measure the full voltage and current of all units in the rack. It can protect the battery according to its own algorithm. Rack SOC (State of Charge) and SOH (State of Health) are also calculated automatically and updated very precisely by the rack BMS.

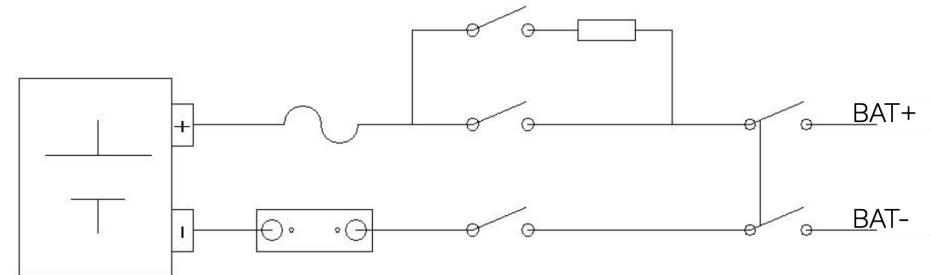

AMP-0001-SMEK - LOCAL CONTROLLER CABINET

The Local Controller Communication cabinet is specifically developed for energy storage power plants. It is integrated with functions of UPS (Uninterrupted Power Supply), power plant data collection and operation control, LCD display of operation data, upload of plant data and more.

RATED INPUT VOLTAGE	380Vac
AC OUTPUT POWER	/
ETHERNET CONFIGURATION	Network switch (10M / 100M / 1000M)
4G COMMUNICATION	Yes, Function reserved
RS485 COMMUNICATION	10 Ports (with isolation)

RS232 COMMUNICATION	1 Port (only for debugging)
INPUT DETECTION CONFIGURATION	16 (Extended to 72)
OUTPUT DRY CONTACT CONFIGURATION	16 (NO + NC)
COMMUNICATION PROTOCOL	Rack BMS: CAN; TOCOL
DISPLAY	HD Touch LCD

AMPIFARM™ CONTAINER



EQUIPMENT	SPECIFICATION / MODULE	UNIT	QTY	REMARK
CONTAINER BODY	20ft HC, high cube container	Set	1	1, Six sides of insulation, the thickness of the insulation layer shall not be less than 50mm 2, including lighting and power distribution
AIR CONDITIONER	7.5KW Industrial A/C	Set	2	Air conditioning power supply lines need to be concealed. Air conditioning communication port needs to be connected to Local controller cabinet
FIRE PROTECTION SYSTEM	Heptafluoropropane fire extinguishing system	Set	1	Including fire controller, Heptafluoropropane, smoke sensors, temperature sensors, alarm and other fire control systems
CONTAINER APPEARANCE		Set	1	Optional custom wrapping

* System co-branding is optional

AMPIFARM™ ESS

AMPIFARM - 500 KW / 1.327 MWH ESS

The AmpifARM™ Series Energy Storage System integrates with the Battery, BMS, PCS to deliver a total power delivery of 1.33 MWh. The AmpifARM™ is housed in a 40ft containerized housing which employs a unique air duct design, resourceful temperature control technology and state of the art FM200 fire suppression.

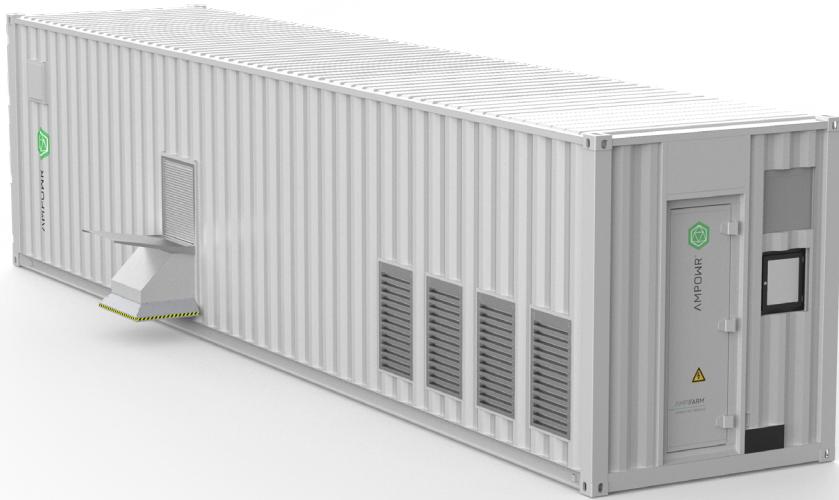

NO.	ITEM	SPECIFICATION	QTY	REMARK
1	AMPIFARM	500kW PCS / Battery 1327kWh	1	Including 11~1.6
1.1	Power Converter System (PCS)	AMP-T005-ESG, 500kW, 400Vac, 3Ph+PE+N	1	
1.2	Local Controller	Local controller cabinet ; AMP-0001-SMEK	1	V
1.3	Battery System (Battery rack)	165.8kWh; 3.2V/120Ah, LFP; 18 Battery modules + 1 control box	8	Module: 2P12S, 9.216kWh; Rack: (2P12S) 18S, 165.8kWh; Total Energy: 1327kWh
1.4	Battery System (BMS)	Matched with battery system, including control cabinet	1	Module: 2P12S, 9.216kWh; Rack: (2P12S) 18S, 165.8kWh; Total Energy: 1327kWh
1.5	Container Enclosure	40' container with PCS chamber and battery chamber (including lighting and power distribution)	1	40ft container
1.6	Container HVAC	20kW	2	
1.7	Container Firefighting System	Including fire controller, FM200, smoke sensing, temperature sensing, alarm and other fire control systems	1	
1.8	DC Combiner Cabinet	AMP-8-1-SCDK	1	
1.9	AC&DC Cable	Cables for module connection	/	All required cables included
TOTAL PCS CAPACITY (MW)			0.5	
TOTAL BATTERY CAPACITY (MWH)			1.327	



DATASHEET

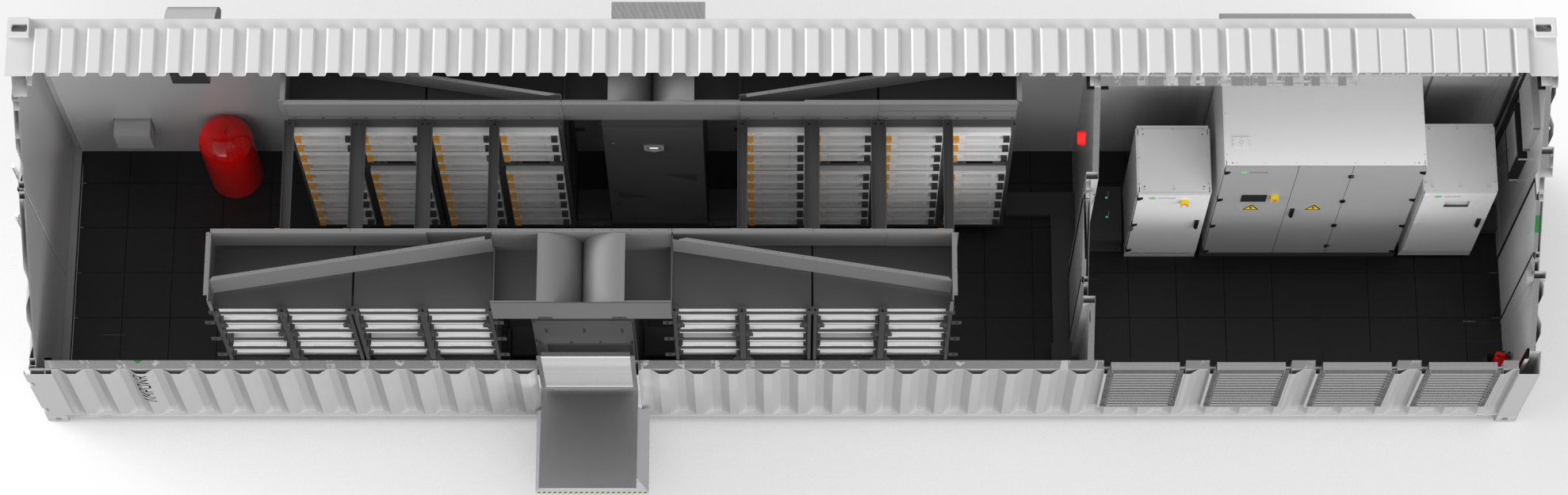

BATTERY SILO

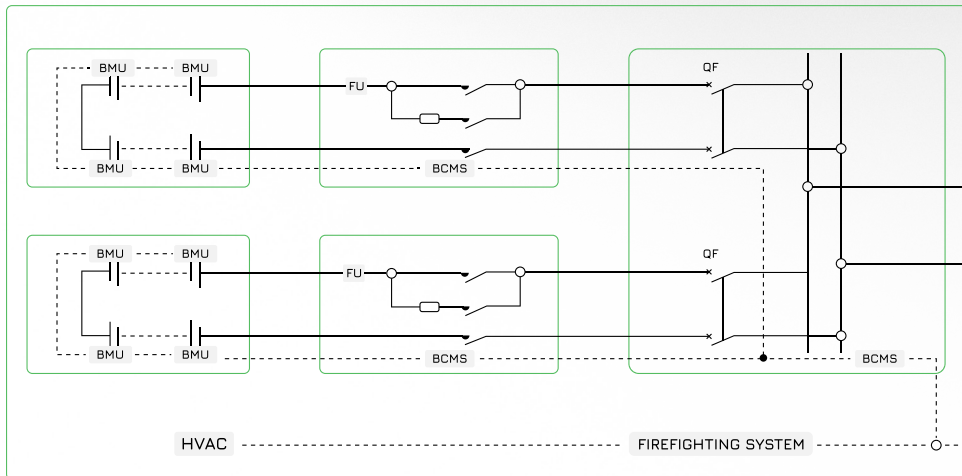

PCS SILO

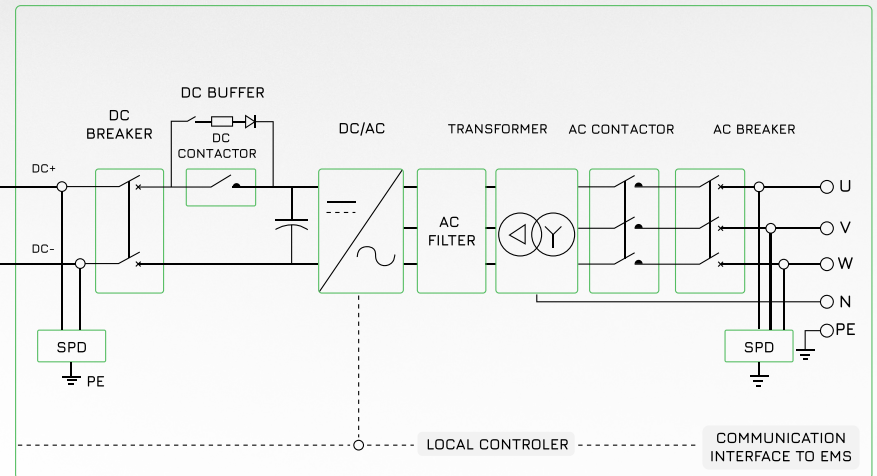

POWER CONDITIONING SYSTEM

AMP-T005-ESG (PCS)

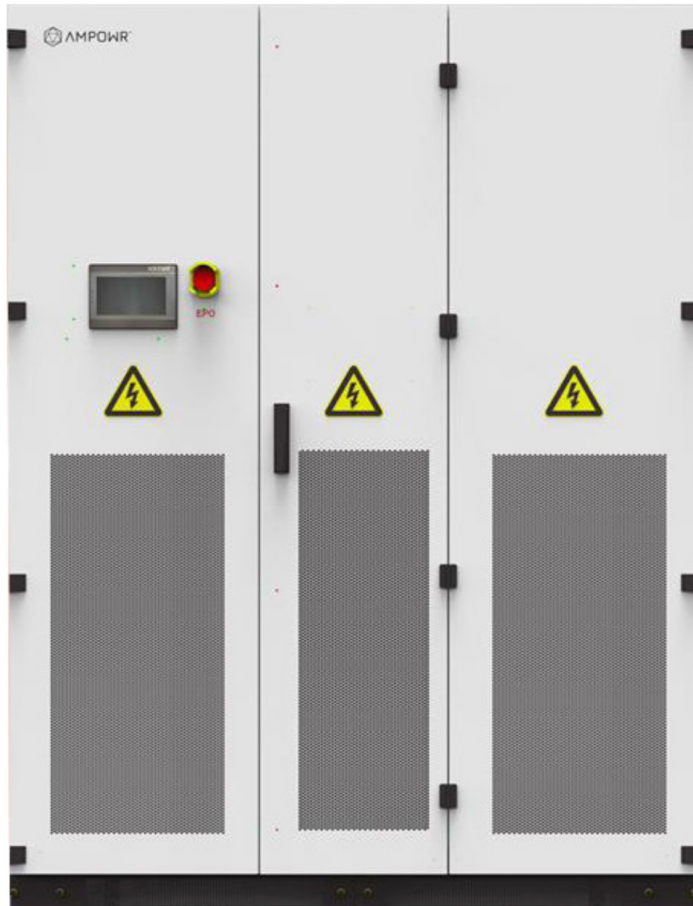

DC SIDE

MAX. DC VOLTAGE	1000 V
DC VOLTAGE RANGE FOR NOMINAL POWER	500 ~ 850Vdc
MAX. DC CURRENT	1128A
AUTO-BUFFER FUNCTION	Yes

AC SIDE (GRID)

AC OUTPUT POWER	500kW
MAX. AC POWER	550kVA
MAX. AC CURRENT	794A
NOMINAL AC VOLTAGE	400Vac, 3W+N+PE
AC VOLTAGE RANGE	400Vac (-20% ~ +15%)
NOMINAL GRID FREQUENCY (GRID FREQUENCY RANGE)	50/60Hz (± 2Hz)
AC CURRENT THD (TOTAL HARMONIC DISTORTION)	<3%
POWER FACTOR AT NOMINAL POWER	>0.99/1 leading - 1 lagging
ADJUSTABLE REACTIVE POWER	-100% ~ 100%

AC SIDE (OFF-GRID)

NOMINAL AC VOLTAGE	400Vac, 3W+N+PE
AC VOLTAGE RANGE	400Vac (-20% ~ +15%)
AC VOLTAGE THD	<3% (Linear load)
UNBALANCELOAD CAPACITY	100%
OVER-LOAD CAPACITY	110% ~ normal operation, 120% ~ 1min

EFFICIENCY

MAX. EFFICIENCY	>97.5%
-----------------	--------

PROTECTION

OVER VOLTAGE PROTECTION	DC Type II / AC Type II
GRID MONITORING / GROUND FAULT MONITORING	Yes
INSULATION MONITORING	Yes
OVERHEAT PROTECTION	Yes

GENERAL DATA

DIMENSIONS (W X H X D)	1600 x 935 x 2000mm (63 x 36.8 x 78.7 inch)
WEIGHT	2200kg (4850lbs)
BYPASS ATS MODULE	No
ISOLATION METHOD	Transformer
CHARGE/DISCHARGE SWITCHING TIME	<40ms
INGRESS PROTECTION RATING	IP21
OPERATING AMBIENT TEMPERATURE RANGE	-30 °C - +55 °C (-22 °F - +131 °F)
RELATIVE HUMIDITY RANGE	0~95% (no condensation)
COOLING METHOD	Intelligent forced air cooling
MAX. OPERATING ALTITUDE	5000m (>3000m derating)
DISPLAY	Touchscreen
COMMUNICATION	RS485 / CAN 2.0 (to BMS), RS485 / Ethernet (to EMS)
GRID SUPPORT	L/HVRT, L / HFRT, active & reactive power control and power ramp rate control

BATTERY SYSTEM

The energy storage system adopts a 3.2V / 120Ah Nano Crystal Battery Cell. The battery cell is packed into a battery module with a voltage of 38.4V and a capacity of 9.216kWh through two parallel strings in a series of 12. 18 modules are connected in series to form a battery rack with a voltage of 691.2V and a capacity of 165.8 kWh. Each battery container system consists of 8 battery banks, with a total energy storage capacity of 1.327MWh.

NCPB3.2-120CL - BATTERY CELL

CAPACITY	≥ 120Ah @ 25 °C (77 °F), 0.25C, BOL	NOMINAL GRID FREQUENCY (GRID FREQUENCY RANGE)	50/60Hz (± 2Hz)
NOMINAL VOLTAGE	3.2V	REVERSIBLE CAPACITY LOSS, 25 °C (77 °F), 100% SOC / MONTH	≤ 3.5%
DIMENSION (W X H X D)	173.9 x 170 x 485mm (6.86 x 6.7 x 19.1inch)	OPERATION TEMPERATURE	-20 °C ~ 55 °C (-4 °F ~ 131 °F)
WEIGHT	≤2.86kg (6.3lbs)	STORAGE TEMPERATURE	-30 °C ~ 60 °C (-22 °F ~ 140 °F)
IMPEDANCE (1KHZ, BOL, 40% SOC)	≤0.3mΩ	CERTIFICATION	IEC 62619, UL1973, UN38.3

NCPB38.4-9.2BP - BATTERY PACK

NOMINAL ENERGY	9.216kWh @25 °C (77 °F), BOL, 2P12S	OPERATION TEMPERATURE	Min. 0 °C (32 °F) - Max. 40 °C (104 °F)
RATED VOLTAGE	38.4V	COOLING METHOD	Air Cooling
VOLTAGE RANGE	Min: 33.6V Max: 43.8V	HUMIDITY	0%~95%, non condensing
WEIGHT	86kg (189.6lbs)	COMMUNICATION PROTOCOL	Rack BMS: CAN;
DIMENSION (H X W X D)	202 x 642 x 676mm (8 x 25.3 x 26.6inch)	Note: CSC (Cel Sensor Circuit) includes passive balancing, cell voltage measurement, temperature measurement.	

BATTERY RACK

CONFIGURATION	(2P12S) 18S	DIMENSION (H X W X D)	2220 x 1080mm x 690 (87.4 x 42.5 x 27.2 inch)
NOMINAL ENERGY	165.8kWh @25 °C (77 °F), BOL, NCPB3.2-120CL	OPERATION TEMPERATURE	Min. 0 °C (32 °F) - Max. 40 °C (104 °F)
RATED VOLTAGE	691.2V	COOLING METHOD	Air Cooling
VOLTAGE RANGE	614.4 ~ 768V	HUMIDITY	0%~95%, non condensing
WEIGHT	<2000 kg (<4409lbs)	COMMUNICATION PROTOCOL	Modbus + CAN

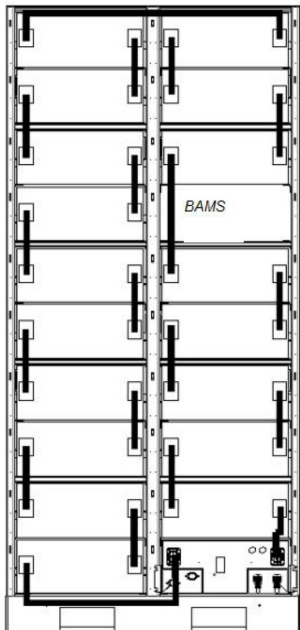

DATASHEET



CONTROL BOX WITH RACK BMS



BATTERY MANAGEMENT SYSTEM

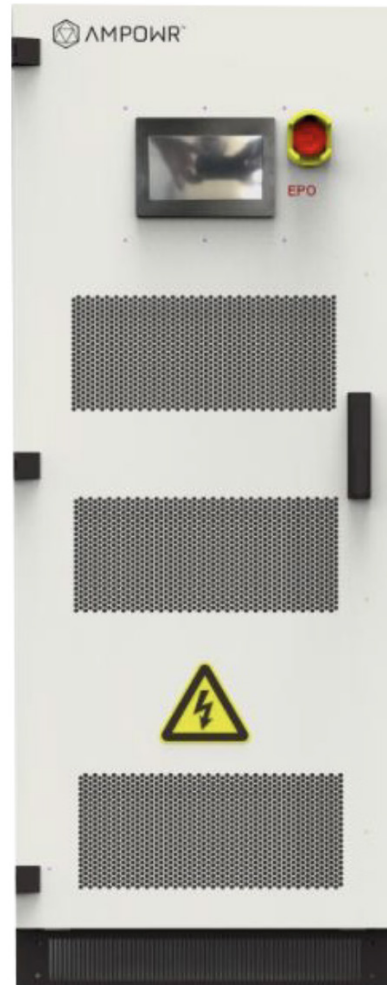

LOCAL CONTROLLER CABINET

BATTERY MANAGEMENT

The rack BMS has the ability to measure the full voltage and current of all units in the rack. It can protect the battery according to its own algorithm. Rack SOC (State of Charge) and SOH (State of Health) are also calculated automatically and updated very precisely by the rack BMS.

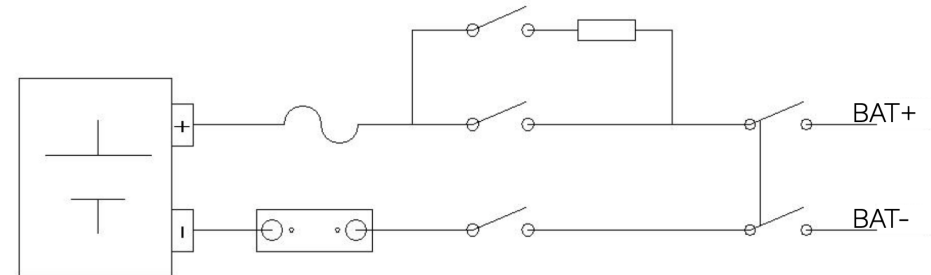

AMP-0001-SMEK - LOCAL CONTROLLER CABINET

The Local Controller Communication cabinet is specifically developed for energy storage power plants. It is integrated with functions of UPS (Uninterrupted Power Supply), power plant data collection and operation control, LCD display of operation data, upload of plant data and more.

RATED INPUT VOLTAGE	380Vac
AC OUTPUT POWER	/
ETHERNET CONFIGURATION	Network switch (10M / 100M / 1000M)
4G COMMUNICATION	Yes, Function reserved
RS485 COMMUNICATION	10 Ports (with isolation)

RS232 COMMUNICATION	1 Port (only for debugging)
INPUT DETECTION CONFIGURATION	16 (Extended to 72)
OUTPUT DRY CONTACT CONFIGURATION	16 (NO + NC)
COMMUNICATION PROTOCOL	Rack BMS: CAN; TOCOL
DISPLAY	HD Touch LCD

AMPIFARM™ CONTAINER

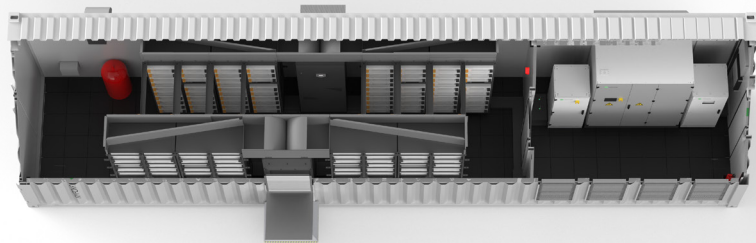

EQUIPMENT	SPECIFICATION / MODULE	UNIT	QTY	REMARK
CONTAINER BODY	40ft HC, high cube container	Set	1	1, Six sides of insulation, the thickness of the insulation layer shall not be less than 50mm 2, including lighting and power distribution
AIR CONDITIONER	20KW Industrial A/C	Set	2	Air conditioning power supply lines need to be concealed. Air conditioning communication port needs to be connected to Local controller cabinet
FIRE PROTECTION SYSTEM	Heptafluoropropane fire extinguishing system	Set	1	Including fire controller, Heptafluoropropane, smoke sensors, temperature sensors, alarm and other fire control systems
CONTAINER APPEARANCE	10 Ports (with isolation)	Set	1	Customer Customized design (front side of ESS)

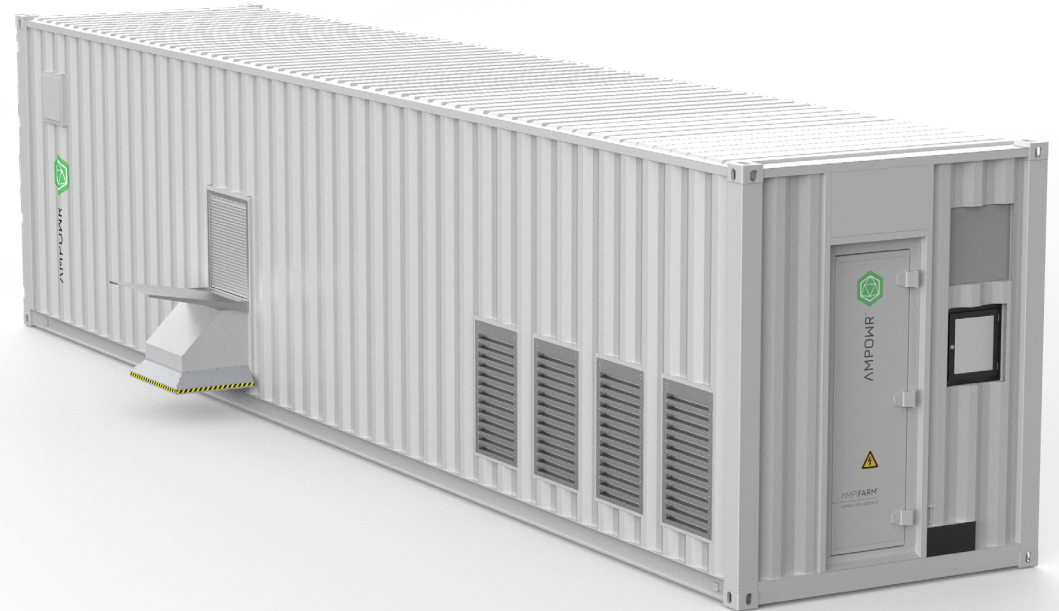

* System co-branding is optional

SOLAR STRING INVERTER (OPTIONAL)

AMP-LC120-GSK

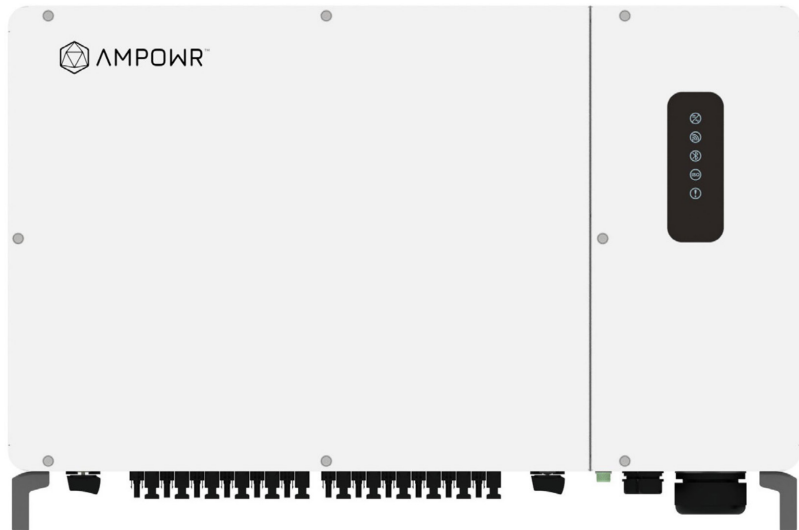

INPUT (DC)

MAX. DC VOLTAGE	1100V
NOMINAL VOLTAGE	620V
START VOLTAGE	200V
MPPT VOLTAGE RANGE	180V-1000V
NUMBER OF MPP TRACKER	10
STRINGS PER MPP TRACKER	2
MAX. INPUT CURRENT PER MPPT	30A
MAX. SHORT-CIRCUIT CURRENT PER MPPT	50A

OUTPUT (AC)

NOMINAL AC OUTPUT POWER	120kW @30 °C (86 °F) / 110kW @40 °C (104 °F) / 100kW @50 °C (122 °F)
MAX. AC APPARENT POWER	121kVA
NOMINAL AC VOLTAGE	400V 3W+N+PE
AC GRID FREQUENCY RANGE	50Hz / 60Hz ±5Hz
MAX. OUTPUT CURRENT	174.6A
POWER FACTOR	0.8 Leading - 0.8 Lagging
THDI	<3%

EFFICIENCY

MAX. EFFICIENCY	98.7%
EURO. EFFICIENCY	98.5%

PROTECTION

DC SWITCH	Yes
ANTI-ISLANDING PROTECTION	Yes
OUTPUT OVERCURRENT PROTECTION	Yes
DC REVERSE-POLARITY PROTECTION	Yes
STRING FAULT DETECTION	Yes
DC SURGE PROTECTION	Type II
AC SURGE PROTECTION	Type II
DC INSULATION RESISTANCE DETECTION	Yes
RESIDUAL CURRENT MONITORING	Yes
AC SHORT-CIRCUIT PROTECTION	Yes

GENERAL SPECIFICATIONS

DIMENSIONS (W X H X D)	1055 x 700 x 336mm (41.5 x 27.6 x 13.2inch)
WEIGHT	93kg (205lbs)
OPERATING TEMPERATURE RANGE	-25 °C ~ +60 °C (-13 °F ~ 140 °F)
COOLING TYPE	Fan Cooling
MAX. OPERATING ALTITUDE	4000m
MAX. OPERATING HUMIDITY	0-100% (No Condensation)
AC OUTPUT TERMINAL TYPE	OT Terminal
IP CLASS	IP66
TOPOLOGY	Transformer-less
COMMUNICATION	RS485 / WiFi / 4G
DISPLAY	LED / Bluetooth + APP